

# TA-12V

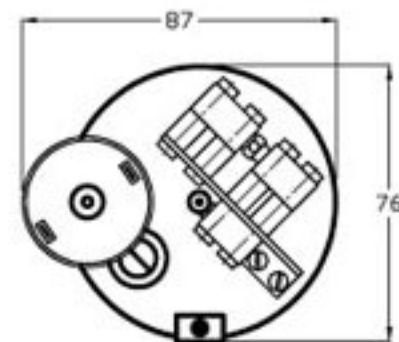

# 540

## How to calculate lengths of a custom made Piston Tank \*

1. Determine operational volume of tank (approx. 7 - 10% of model's displacement)

2. Calculate piston stroke

$$1 \text{ mm of piston stroke} = 3,883 \text{ ml}$$

$$\text{piston stroke} = \frac{\text{operational volume (ml)}}{3,883 \text{ (ml)}}$$

3. Cylinder length A (empty) = piston stroke + 47 mm

4. Total length D (full) = cylinder length + 10 mm<sup>1)</sup> + 16 mm<sup>2)</sup> + piston stroke + safety distance (4 mm)

**For example: Piston Tank with an operational volume 250 ml**

$$\text{piston stroke} = \frac{250 \text{ (ml)}}{3,883 \text{ (ml)}} = 64,38 \text{ mm} + 4 \text{ mm} = 68 \text{ mm (rounded off)}$$

$$\text{cylinder length A (empty)} = 68 \text{ mm} + 47 \text{ mm} = 115 \text{ mm}$$

$$\text{length overall D (full)} = A + 10 + 16 + \text{piston stroke} = 115 + 10 + 16 + 68 = 209 \text{ mm}$$

<sup>1)</sup> Length of connection nozzle.

<sup>2)</sup> Projecting length of piston rod, measured from bearing plate when tank is empty.

\* All data without engagement. Measurements given underlie tolerances and are approximate. Specifications may be subject to change.

