

TAE3

EA/TA

Wiring Diagram

V1217

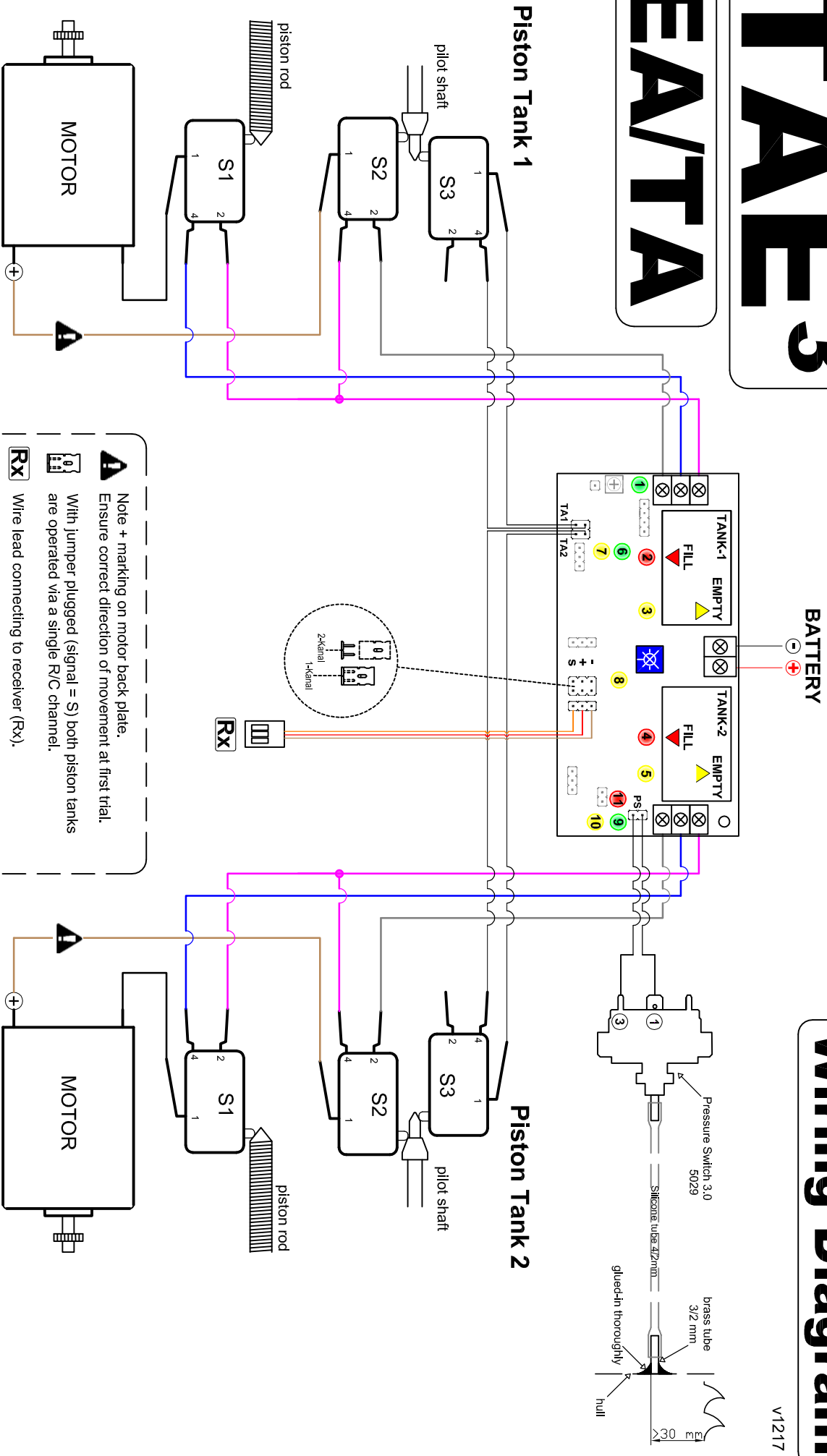

- ⚠** Note + marking on motor back plate. Ensure correct direction of movement at first trial.
- 🔌** With jumper plugged (signal = S) both piston tanks are operated via a single R/C channel.
- Rx** Wire lead connecting to receiver (Rx).
- 1** GREEN LED 1: Pressure Switch activated.
- 6 9** GREEN LEDs 6 & 9: Indicate quality of receiver signal.
- 11** RED LED 11: Low-Battery-Monitor activated (main battery power at or below threshold voltage).
- 🔍** Potentiometer for adjustment of low battery monitor. Turn clockwise for decreasing threshold voltage, turn anti-clockwise to increase.

- PLEASE NOTE:**
- Connections and LEDs not described here are redundant for operation of Piston Tank type EA and TA. These are only applicable with Hall Sensors connected as well as operation with Static Depth Controller TAES. Connections to be made with Hall Sensors are shown in Wiring Diagram HALL.